

PRODUCTS & PARTS

2021-22





Welcome to the FLEX Generation

The modern design of the FLEX makes a bold statement, and the DUO conditioning system under the lid backs it up. DUO Technology gives you the benefit of easily using more than one lane conditioner in your center. By combining the precise accuracy of Sanction Technology™ with dual conditioner cartridges, and still being able to verify how much conditioner will be applied to the lane, DUO Technology gives you versatility, dependability, and accountability.

FLEX gives you features to improve performance, simplify your experience, and allows you to have more control of your lane maintenance program. Want even more? Choose from any of our upgrades for a machine perfectly customized to fit your needs.

FLEX WALKER



17-5803
(115V AC/50-60 Hz)
17-5853
(230V AC/50-60 Hz)

FLEX



17-5707
(115V AC/50-60 Hz)
17-5757
(230V AC/50-60 Hz)

FLEX Machine Weight: 331 lbs. (150.1 kg)

FLEX Walker Machine Weight: 370 lbs. (167.8 kg)

CONDITIONING

- Uses Sanction Technology™ to measure conditioner volume before applying to lane
- Variable Speed Buffer option (see upgrades)
- DUO conditioning system (two pumps and two conditioner cartridges)
- DUO transfer system
- Two pre-filled/refillable conditioner cartridges
- Alternate two conditioners in one pass
- Adjustable microliter streams (per load setting)
- Ability to condition each lane in less than 90 seconds
- Conditioner float switches with low level warning message
- Board-to-board pattern control
- "Oil Only" function
- Touchscreen control of oil pump calibration

CLEANING

- Cleaner Mixing System option (see upgrades)
- Squeegee cartridge for easy replacement of blades
- Sprayless cleaning system
- Ability to monitor and adjust cleaner output in touchscreen
- Cleaner float switches with low level warning message
- Large waste recovery tank (50+ lanes before emptying)
- Duster/cleaning cloth waste roll on top for easy removal
- Patented cushion roller wrap for better cleaning
- Super quiet DC vacuum motor
- "Clean Only" function
- "Dust Only" function

DRIVE

- Patented six variable drive speeds
- Backend adjustable cleaning speed
- Self-adjusting drive speeds
- LED arrow for better operator positioning
- Dual Drive System

TOUCHSCREEN/PLC

- Full color 7" touchscreen display
- Three program zones for both AM and PM
- Stores 30 programs in memory
- Test input/output menu option
- Full detailed error messages

BATTERIES

- Single lightweight lithium battery
- Three battery options based on number of lanes conditioned per day
- External battery charger

SPECIAL FEATURES

- Easy sliding detachable lid assembly
- KOSI™ software kit included (Kegel Online Support Interface)

WALKER ONLY FEATURES

- Zero Turn Radius lane to lane walking function
- Auto-aligning lane whiskers
- Smart processor auto-align memory
- Front safety object detection
- Automatic burn pair



FLEX BONUS WARRANTY

Receive an 18 month warranty with an additional 18 months if you agree to only use Kegel lane maintenance products in your lane machine.

UPGRADES

Cleaner Mixing System*

- Self-mixing cleaner adjustments
- Precise mixing ratios

Variable Speed Buffer*

- Ability to customize four preset buffer speeds
- More control of front to back taper

Batteries

- Each machine comes with our K2 Energy® lithium battery
- Upgrade to larger battery based on number of lanes conditioned per day



158-1634BU
(62 lanes)



158-1634CU
(90 lanes)

* Factory upgrade (must be installed at time of purchase).

** All FLEX Machines come standard with battery 158-1634BU.

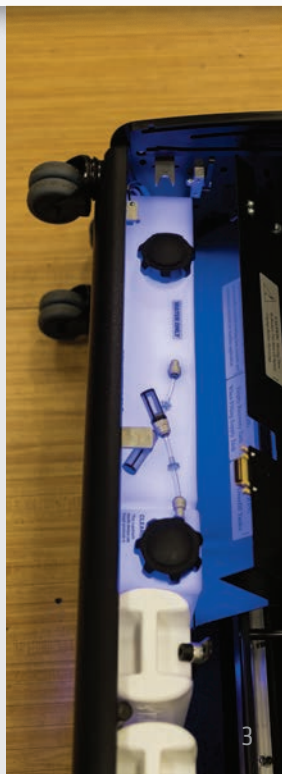



High Tech Made Easy

IKON is a battery powered combination lane machine that incorporates Kegel's proven technology with the modern styling of the FLEX.

The IKON uses Sanction Technology™ for the conditioning system which is reliable, verifiable, and accurate to ±1% with continued precision of ±0.5% after millions of cycles.

For cleaning, the IKON utilizes a sprayless system, which cleans the lane without any overspray into the gutters, keeping your customers and pinsetters cleaner.

Kegel's patented conditioning and cleaner systems are the only ones that can be checked and verified before you begin lane maintenance - now that's peace of mind.

IKON WALKER



TECHNICAL SPECIFICATIONS

- Part Number:
17-6400 (115V AC/50-60 Hz)
17-6450 (230V AC/50-60 Hz)
- Weight without the battery: 350 lbs. (167.8 kg)

IKON



TECHNICAL SPECIFICATIONS

- Part Number:
17-5900 (115V AC/50-60 Hz)
17-5950 (230V AC/50-60 Hz)
- Weight without the battery: 330 lbs. (149.7 kg)

IKON / IKON WALKER Battery Specifications

158-1634 (Red) 25.6 Ah | 24 lbs (10.8 Kg) - Standard
 158-1634BU (Orange) 38.4 Ah | 29 lbs (13.1 Kg) - Upgrade
 158-1634CU (Yellow) 51.2 Ah | 39 lbs (17.6 Kg) - Upgrade

FEATURES

- Sanction Technology™ Conditioning System with forward and reverse capabilities
- DUO Transfer System enhances the smoothness of the pattern and allows for easy pattern changes
- Patented sprayless cleaning system
- Full color 3.5" touchscreen display
- PLC stores 15 patterns in memory
- Choose from 3 different size lithium batteries based on your bowling center's needs or number of lanes conditioned per day
- Conditions each lane in less than 90 seconds

WALKER ONLY FEATURES

- Zero Turn Radius lane to lane walking function
- Auto-aligning lane whiskers
- Smart processor auto-align memory
- Front safety object detection



IKON BONUS WARRANTY

Receive an 18 month warranty with an additional 18 months if you agree to only use Kegel lane maintenance products in your lane machine.



Affordable Quality

The Crossfire is a compact, durable and highly functional lane machine at a very affordable price. This wick combination lane machine allows small centers to experience high quality lane maintenance only Kegel can deliver.

Features:

- Cleans and conditions the lane in about 80 seconds
- On-board keypad for simple machine programming
- 6 High-Flow Wick Pads (upgradeable to 8)
- 12 Lane Conditioner Capacity (upgradeable to 60)
- 32 Lane Cleaner Capacity
- 3 Drive Speeds for enhanced pattern taper
- Compact Design
- Full color 3.5" touchscreen display
- Machine Weight: 275 lbs. (124.7 kg)



Part Number:

Crossfire - 6 PAD MODEL D

17-5200D (115V AC/60 Hz) 6 PAD/CAM MACHINE

17-5250D (230V AC/50 Hz) 6 PAD/CAM MACHINE

Optional Upgrade Kit

Increase to 8 Wick Pads and Conditioner Capacity to 60 lanes

158-8241 - 8-PAD AND CONDITIONER TANK UPGRADE KIT - 115V AC

158-8241E - 8-PAD AND CONDITIONER TANK UPGRADE KIT - 230V AC

158-8214 - 8-PAD UPGRADE KIT

158-8215 - CONDITIONER TANK UPGRADE KIT - 115V AC

158-8215E - CONDITIONER TANK UPGRADE KIT - 230V AC



Lane Machine Assist

One person can quickly and easily raise and lower their lane machine safely.

Physical Properties:

- Color: Black
- Dimensions: Width: 60" | Height: 8" | Depth: 8"
- Lifting Capacity: Any Kegel Lane Machine
- Packaging: Assembled and ready to mount

Part Number: 154-8510

(Must be installed by a qualified contractor.)

Bracket Kit for all models

Part Number: 154-8520

Replacement Strap Kit

Part Number: 154-8519

LANE MACHINE COMPARISON CHART

	FLEX WALKER	FLEX	IKON WALKER	IKON	CROSSFIRE
CONDITIONING					
Sanction Technology™ fluid metering conditioning system	✓	✓	✓	✓	
Conditions each lane in less than 90 seconds	✓	✓	✓	✓	✓
Conditioner float switches with low level warning message	✓	✓	✓	✓	OPTIONAL
"Oil Only" function	✓	✓	✓	✓	✓
Touchscreen control of microliter stream	✓	✓			
Touchscreen control of oil pump calibration	✓	✓			
DVO conditioning system (two pumps and two conditioner cartridges)	✓	✓			
DVO transfer system (roller and single transfer brush)	✓	✓	✓	✓	
Two pre-filled/refillable conditioner cartridges	✓	✓			
Ability to alternate two conditioners in one pass	✓	✓			
Board-to-board pattern control	✓	✓	✓	✓	
Measure conditioner volume per board stream before applying to lane	✓	✓	✓	✓	
Adjustable microliter streams (per load setting)	✓	✓			
Ability to run multiple conditioners	✓	✓			
4 Variable Buffer speeds	OPTIONAL	OPTIONAL			
CLEANING					
Sprayless cleaning system	✓	✓	✓	✓	
Cleaner float switches with low level warning message	✓	✓	✓	✓	✓
Large waste recovery tank (50+ lanes before emptying)	✓	✓	✓	✓	
Duster/Cleaning cloth waste roll on top for easy removal	✓	✓	✓	✓	✓
Patented cushion roller wrap for better cleaning	✓	✓	✓	✓	✓
Ultra quiet DC vacuum motor	✓	✓	✓	✓	
"Clean Only" function	✓	✓	✓	✓	✓
"Dust Only" function	✓	✓			
Adjustable "End Cleaning" and "Return" distance	✓	✓	✓	✓	✓
Multi-adjustment squeegee assembly	✓	✓	✓	✓	
Squeegee cartridge for easy replacement of blades	✓	✓	✓	✓	
Touchscreen control of cleaner pump calibration	✓	✓	✓	✓	
Recovery tank with handles for better transporting/emptying	✓	✓	✓	✓	✓
Self-mixing cleaner system	OPTIONAL	OPTIONAL			
DRIVE					
Patented six variable drive speeds	✓	✓	✓	✓	
Backend adjustable cleaning speed	✓	✓	✓	✓	
Self-adjusting drive speeds	✓	✓			
Zero Turn Radius lane to lane walking function	✓		✓		
Auto-aligning lane whiskers	✓		✓		
Smart processor auto-align memory	✓		✓		
Front safety object detection	✓		✓		
LED arrow for better operator positioning	✓	✓			
KEYPAD/PLC					
Full color touchscreen display	7"	7"	3.5"	3.5"	3.5"
Number of program zones for AM and PM	3	3	1	1	
Automatic burn pair	✓	✓			
Programs stored in memory	30	30	15	15	4
Test input/output menu option	✓	✓	✓	✓	✓
Type of error messages	FULL DETAIL	FULL DETAIL	SIMPLE	SIMPLE	SIMPLE
SPECIAL FEATURES					
KOSI™ software kit included (Kegel Online Support Interface)	✓	✓	✓	✓	
Wi-Fi Connectivity Kit	✓	✓	✓	✓	
3 lithium battery options based on number of lanes conditioned per day	✓	✓	✓	✓	

Lane Conditioners



SANCTION® CONDITIONERS

Whether you want more hook, less hook, or something in-between, the perfect lane condition is up to you



CURRENT™

- Viscosity: 52.0 cps.
- Surface Tension: 23.3 dyn/cm
- Shipping Weight: 40 lbs. (18.1 kg)
- One Container: 1.25 gallon (4.73 liters)
- Packaging: 4 containers per case
5 gallons (19 liters)

Part Number: 156-8175



TERRAIN™

- Viscosity: 81.0 cps.
- Surface Tension: 33.3 dyn/cm
- Shipping Weight: 40 lbs. (18.1 kg)
- One Container: 1.25 gallon (4.73 liters)
- Packaging: 4 containers per case
5 gallons (19 liters)

Part Number: 156-8185



- Shipping Weight: 38.5 lbs. (17.4 kg)
- One cartridge: 0.4 gallons (1.5 liters)
- Packaging: 12 cartridges per case
4.75 gallons (18 liters)

Part Number: 156-8175C



- Shipping Weight: 38.5 lbs. (17.4 kg)
- One cartridge: 0.4 gallons (1.5 liters)
- Packaging: 12 cartridges per case
4.75 gallons (18 liters)

Part Number: 156-8185C



FIRE™

- Viscosity: 45.1 cps.
- Surface Tension: 23.6 dyn/cm
- Shipping Weight: 40 lbs. (18.1 kg)
- One Container: 1.25 gallon (4.73 liters)
- Packaging: 4 containers per case
5 gallons (19 liters)

Part Number: 156-8135



ICE™

- Viscosity: 40.9 cps.
- Surface Tension: 23.2 dyn/cm
- Shipping Weight: 40 lbs. (18.1 kg)
- One Container: 1.25 gallon (4.73 liters)
- Packaging: 4 containers per case
5 gallons (19 liters)

Part Number: 156-8130



- Shipping Weight: 38.5 lbs. (17.4 kg)
- One cartridge: 0.4 gallons (1.5 liters)
- Packaging: 12 cartridges per case
4.75 gallons (18 liters)

Part Number: 156-8135C



- Shipping Weight: 38.5 lbs. (17.4 kg)
- One cartridge: 0.4 gallons (1.5 liters)
- Packaging: 12 cartridges per case
4.75 gallons (18 liters)

Part Number: 156-8130C

Lane Conditioners

SANCTION® CONDITIONERS



CURVE™ LANE CONDITIONER

- Viscosity: 41.0 cps.
- Surface Tension: 22.0 dyn/cm
- Shipping Weight: 40 lbs. (18.1 kg)
- One Container: 1.25 gallon (4.73 liters)
- Packaging: 4 containers per case 5 gallons (19 liters)

Part Number: 156-8145



- Shipping Weight: 38.5 lbs. (17.4 kg)
- One cartridge: 0.4 gallons (1.5 liters)
- Packaging: 12 cartridges per case 4.75 gallons (18 liters)

Part Number: 156-8145C



INFINITY™ LANE CONDITIONER

- Viscosity: 36.5 cps.
- Surface Tension: 23.1 dyn/cm
- Shipping Weight: 40 lbs. (18.1 kg)
- One Container: 1.25 gallon (4.73 liters)
- Packaging: 4 containers per case 5 gallons (19 liters)

Part Number: 156-8115



DEFENSE-S®

- Viscosity: 47.3 cps.
- Surface Tension: 22.7 dyn/cm
- Shipping Weight: 40 lbs. (18.1 kg)
- One Container: 1.25 gallon (4.73 liters)
- Packaging: 4 containers per case 5 gallons (19 liters)

Part Number: 156-8025

WICK-PAD & SANCTION® CONDITIONERS



PRODIGY® LANE CONDITIONER

- Viscosity: 31.2 cps.
- Surface Tension: 23.7 dyn/cm
- Shipping Weight: 40 lbs. (18.1 kg)
- One Container: 1.25 gallon (4.73 liters)
- Packaging: 4 containers per case 5 gallons (19 liters)

Part Number: 156-8095



NAVIGATE™ LANE CONDITIONER

- Viscosity: 31.3 cps.
- Surface Tension: 23.5 dyn/cm
- Shipping Weight: 40 lbs. (18.1 kg)
- One Container: 1.25 gallon (4.73 liters)
- Packaging: 4 containers per case 5 gallons (19 liters)

Part Number: 156-8125



- Viscosity: 24.1 cps.
- Surface Tension: 23.6 dyn/cm
- Shipping Weight: 40 lbs. (18.1 kg)
- One Container: 1.25 gallon (4.73 liters)
- Packaging: 4 containers per case 5 gallons (19 liters)

Part Number: 156-8105

Conditioner Comparison

SANCTION TECHNOLOGY™									
PROPERTIES	TERRAIN	CURRENT	FIRE	ICE	CURVE	NAVIGATE	INFINITY	PRODIGY	DEFENSE-S
VISCOSITY <small>(at 72.5 °F / 22.8 °C)</small>	81	52	45.1	40.9	41	31.3	36.5	31.2	47.3
CHARACTERISTICS									
Lineage (Best for)	Any	Any	League / Tournament	League / Tournament	League	Open Play / League	League / Tournament	Open Play	League
Average Pin Calls	Low/None	Low/None	Low/ Medium	Low/ Medium	Low	Low	Medium	Low/None	High
Cleanability	Moderate	Difficult	Easy	Easy	Moderate	Easy	Moderate	Easy	Difficult
LANE SURFACES									
High Friction Surfaces	Better	Best	Good	Best	Better	Better	Best	Better	Best
Medium Friction Surfaces	Best	Best	Better	Better	Best	Better	Better	Best	Better
Low Friction Surfaces	Best	Better	Best	Good	Better	Better	Good	Best	Good

WICK-PAD TECHNOLOGY			
PROPERTIES	NAVIGATE	PRODIGY	CROSSFIRE
VISCOSITY <small>(at 72.5 °F / 22.8 °C)</small>	31.3	31.2	24.1
WICKING TIME	13 minutes	14 minutes	10 minutes
CHARACTERISTICS			
Lineage (Best for)	Open Play / League	Open Play	Open Play / League
Average Pin Calls	Low	Low	Low
Cleanability	Easy	Easy	Easy
LANE SURFACES			
High Friction Surfaces	Good	Better	Best
Medium Friction Surfaces	Better	Better	Best
Low Friction Surfaces	Better	Best	Good

Lane Cleaners



DEFENSE CX4 S

- Designed for low friction surfaces and stronger backend reaction
 - pH: 11.5
 - Shipping Weight: 10 lbs. (4.5 kg)
 - One Container: 1 Gallon (3.79 liters)
 - Packaging: 1 container per case
- Part Number: 156-8435



DEFENSE-C

- pH: 12.6
 - Shipping Weight: 46 lbs. (20.8 kg)
 - One Container: 2.5 gallons (9.4 liters)
 - Packaging: 2 containers per case
- Part Number: 156-8405



DEFENSE CX4

- Designed for high friction surfaces
 - pH: 12.8
 - Shipping Weight: 10 lbs. (4.5 kg)
 - One Container: 1 Gallon (3.29 liters)
 - Packaging: 1 container per case
- Part Number: 156-8425

Cleaner Cloth

EZ Core Technology makes changing cloth "Quick & EZ"! Stop handling dirty cloth and get ultimate cleaning results.

K2 Select Cleaner Cloth

- Color: White
- Roll Dimensions: 43" wide x 20 yards long
- Shipping Weight: 16 lbs. (7.2 kg)
- Packaging: 4 rolls per case

K3 Select Cleaner Cloth

- Color: White
- Roll Dimensions: 43" wide x 30 yards long
- Shipping Weight: 16 lbs. (7.2 kg)
- Packaging: 3 rolls per case
- Compatible with: Kustodian Plus and later model lane machines (Not compatible with Crossfire Lane Machines)

Part Number:

K2 Select (Reusable PVC Core): 153-0047EZ

K3 Select (Reusable PVC Core): 164-0047EZ

K2 Kloth (Cardboard Core): 153-0047P

K3 KLOTH
Clean up to
50% more
lanes before
changing
rolls



No-Spill[®] Tank Fill



With No Spill[®] Tank Fill containers, you can quickly and easily fill your tanks with no mess. Just press the button and the auto-stop feature of the nozzle helps prevent overfilling.

For lane machines with the cleaner mixing system upgrade, use the 2.5 gallon container for water and the 1.25 gallon container for cleaner. For a standard cleaner tank, pre-mix your cleaner in the No Spill[®] Tank Fill container using the mixing guide on the label.

Part Number:

No Spill Tank Fill Kit

(2.5 & 1.25 Gal For Cleaner Upgrade Machines) - 164-8661

No Spill Tank Fill - 2.5 GAL - 164-8662

No Spill Tank Fill - 1.25 GAL - 164-8663

Nozzle For No Spill Tank Fill - 164-0218

O-Ring For No Spill Tank Fill Nozzle - 164-0219



Center Care Products



Spot On[™] Pin Deck Spray

Spot On Pin Deck Spray helps you improve pin carry to eliminate off-spot pins and out-of-ranges. Purchase the gallon size which can be used manually with your favorite spraying device!

- One Container: 1 gallon (3.79 liters)
- Packaging: 1 container per case

Part Number: 156-8311



Balance[™] Approach All-In-One

Balance is the all-in-one solution to maximize the performance of your synthetic approaches. With one product you can create an even and uniform surface for optimal slide conditions. Clean and condition your approaches in one simple application.

Use with a rotary buffer.

- One Bottle: 16 oz. (0.47 liters)
- Packaging: 4 bottles per case

Part Number: 156-8320



Microfiber Approach and Utility Mops

Color-coded to separate your approach mops from other mops used in less sensitive areas of your center. These high performance microfiber mops grab dirt and dust for quick and easy cleaning. Approach Mop is ideal for synthetic approaches. Utility Mop is perfect for cleaning in the pit, bowlers area, and elsewhere throughout your center. Machine-washable.



Approach Mop (Green)

- 36" Approach Mop only - 159-4402
- 36" Approach Mop with Handle Assembly - 159-4402C
- 48" Approach Mop only - 159-4403
- 48" Approach Mop with Handle Assembly - 159-4403C



Approach Mop (White)

- 24" Approach Mop only - 159-4420
- 24" Approach Mop with Handle Assembly - 159-4420C
- 36" Approach Mop only - 159-4421
- 36" Approach Mop with Handle Assembly - 159-4421C
- 48" Approach Mop only - 159-4422
- 48" Approach Mop with Handle Assembly - 159-4422C



Utility Mop (Blue)

- 18" Utility Mop only - 159-4410
- 18" Utility Mop with Handle Assembly - 159-4410C
- 24" Utility Mop only - 159-4411
- 24" Utility Mop with Handle Assembly - 159-4411C
- 36" Utility Mop only - 159-4412
- 36" Utility Mop with Handle Assembly - 159-4412C

Industrial Approach Mop



This industrial white approach mop is made of durable non-looped cotton strands that easily lift away dirt and dust. Recommended for wood approaches. Machine-washable.

- 24" Approach Mop only (White) - 159-4430
- 24" Approach Mop with Handle Assembly - 159-4430C
- 36" Approach Mop only (White) - 159-4431
- 36" Approach Mop with Handle Assembly - 159-4431C
- 48" Approach Mop only (White) - 159-4432
- 48" Approach Mop with Handle Assembly - 159-4432C

Gutter Mop



This white gutter mop is made of durable non-looped cotton strands. Recommended for all type gutters. Machine-washable.

- Gutter Mop - 159-4400
- Gutter Mop Frame and Handle only - 159-4400F
- Gutter Mop Complete with Frame and Handle - 159-4400C

Frames and Jaws

- 18" Wire Frame - 159-4450
- 24" Wire Frame - 159-4451
- 36" Wire Frame - 159-4452
- 48" Wire Frame - 159-4453
- Handle Assembly Only - 159-4455

Buffing Pads



Buffing Pad (White)

This 21" buffing pad is made with absorbent synthetic blended yarn. Gently clean away dust from less textured approaches. Machine-washable.

Part Number: 159-4511



Buffing Pad (Green & White)

With green scrubbing stripes on both sides, this 21" buffing pad offers a little something extra. Perfect for more textured approach surfaces, this buffing pad allows you to gently loosen and remove dirt build-up from the pores of your approach. Machine-washable.

Part Number: 159-4510



PIN CLEANING MACHINE & CLEANER CONCENTRATE

- Cleans ALL types of bowling pins
- Includes attachment to sand base of pins
- Weight: 37 lbs. (16.7 kg)

Part Number:

17-0040 – 115V AC/60 Hz

17-0040E – 230V AC/50 Hz



- Cleans ALL types of bowling pins
- Not harmful to skin
- For use in ALL pin cleaning machines
- One Container: 1 gallon (3.79 liters)
- Packaging: One container per case
- Concentrated cleaner
- pH: 9.2

Part Number: 156-8800



- pH: 8.4
- Easy to use - spray on, wipe off
- Gentle on the skin
- Can be used on ALL bowling balls

Part Number:

156-8768 - 8oz. (0.236 liters) bottle

156-8768C - Case (12 - 8oz. bottles)

156-8762 - 32oz. (0.9 liters) bottle



Kegel Heavy Duty Hand Cleaner removes stubborn industrial soils, grease, oil, tar, paint, and even lane oil from the skin without harsh solvents.

162-8501: 2.5 Liter Bottle w/Dispenser

162-0500: 2.5 Liter Hand Cleaner Refill (for use with dispenser)

162-0501: Hand Cleaner Dispenser

162-0504: 13.5 oz. Bottle





The Disposable Alternative to Bowling Rental Shoes

Bowling Buddies™ Shoe Covers are fully functional, disposable shoe covers that are designed for a single session of bowling and are intended as an alternative to the traditional rental shoe.

SHOE SIZE CHART				
SIZE	PART NUMBER	KID'S	WOMEN'S	MEN'S
SMALL	159-4600	2 & Under		
MEDIUM	159-4601	2+	8 & Under	
LARGE	159-4602		8.5 - 12	5.5 - 9.5
X-LARGE	159-4603		13+	10-15
VARIETY PACK	159-4604	SMALL= 50	MEDIUM= 75	LARGE= 75 X-LARGE= 50

Packaging: Each case contains 250 individually wrapped pairs of the selected size.

MICRO STRIKER

Advanced House Ball and Multi Purpose Cleaner for Bowling Centers

Micro Striker comes in a tablet form and mixes up fresh into a powerful cleaning solution containing active chlorine. Each tablet can make one 24-ounce bottle of cleaner.



Part Number:

156-8861 - Micro Striker Starter Kit
(Two 24-ounce continuous mist spray bottles & 50 tablets)

156-8860 - Micro Striker Refill Tablets
(50 Tablets)

156-8862 - Micro Striker Bottle & Sprayer
(One 24-ounce continuous mist spray bottle)

pH: 6



Coaching Tools



Controller and Protection Guard are not pictured.

Specto is the premier tracking system for centers, bowlers, and coaches. It records information about bowlers' shots using an advanced sensor and displays it to them on an easy-to-use app. The free mobile app for iOS or Android also includes the game-like modules Worlds and Challenges for a fun, customizable experience.

Specto Complete System - 157-8602 (90V AC - 260V AC / 50-60 Hz)

Scan this QR Code to see Specto Requirements for your center

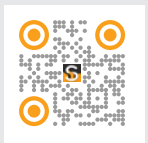

Specto Go is a portable version of the tracking and practice system for centers, bowlers, and coaches. With all the great features of Specto and the added benefit of being able to take it on the go, this system is perfect for temporary set-ups and can be moved between different locations.

Specto GO Tracking System - 157-8611 (90V AC - 260V AC / 50-60 Hz)

Specto and Specto Go require a \$495 annual fee which provides continuous software and mobile app updates.





The Torch is a light targeting tool used to help with accuracy and alignment. Using LED lights, it reflects a path of light on the lane to help you select the correct launch angle and hit your target time after time.

Torch Complete System - 157-8800 (100V AC - 240V AC / 50-60Hz)

Upgrades

Torch 2-Piece Adjustable Height System Upgrade - White Light - 157-8808

Torch Tilt Bar System Upgrade - 157-8809

Torch Light Trigger System Upgrade - 157-8816

Torch Tilt Bar & Light Trigger System Upgrade with Color - 157-8817

Optional Battery Upgrade - 157-8801

Replacement Parts

Torch Battery Charger Assembly - 157-8805

2 Foot White LED Light (Middle) - 157-8806

3 Foot White LED Light (Top) - 157-8807

4 Foot White LED Light (Bottom) - 157-8802

5 Foot White LED Light (Top) - 157-8803

Power Supply - 157-1805A

Dimmer - 157-1806A

Power Cord (9.8ft DC) - 157-1808



Torch-X Features:

- Multiple light color options
- Tilt bar for precision alignment
- 2-piece top assembly for height adjustments
- Trigger switch flashes light on and off when you hit your target

Torch-X Lane Complete System - 157-8810 (100V AC - 240V AC / 50-60Hz)



The Arrow is a 3D Reference Tool that gives players a physical reference point to see when working on a variety of drills. Visualize your set-up position, pushaway, finish position and more!

Arrow - 157-8850



Bowling Ball is not included.

LEGEND

SUFFIX	MACHINE	SUFFIX	MACHINE
IKW	IKON WALKER	KW	KUSTODIAN WALKER
IKN	IKON	ION	KUSTODIAN ION
FWYEAR*	FLEX WALKER YEAR	XF	CROSSFIRE
FXYEAR*	FLEX YEAR	KP	KUSTODIAN PLUS
FXW	FLEX WALKER 2013-15	KK	KUSTODIAN
FLX	FLEX 2013-15	PX-C	PHOENIX C

Some models have been discontinued, making some parts unavailable. Models include Elite (ELT), Standard (STD), Elite Plus (EP), Phoenix (PX), Phoenix-S (PXS)

* YEAR represents the model year in the serial number. Suffix represents all model variations unless model type is specifically indicated (i.e. KP-A).

Cleaning

Recovery Tank - 164-8017 IKW | IKN | FXW | FLX
Recovery Tank Filter (for tank 164-8017)
 164-8017F - IKW | IKN | FXW | FLX (FLX-17733 / FXW-13229 and ABOVE)

Recovery Tank - 153-8841 - XF
Recovery Tank Filter (for tank 153-8841) - 153-8844 - XF
Recovery Tank - 154-8683 - ION-A | KP-A | KK | PX-C
Folded Recovery Tank Filter (for tank 154-8683) - 154-8684

Recovery Tank - 158-8434 - ION-B | KP-B
Recovery Tank - 158-8617 - KW | ION-C,D
Recovery Tank Filter (for tanks 158-8434, 158-8617) - 158-0406
Recovery Tank Gasket (for tanks 158-8434, 158-8617, 164-8017) - 158-0405



Upgraded Cleaner Mixing System

Complete Cleaner Tank Assembly - 164-8043
Complete Water Tank Assembly - 164-8041
Cleaner Pump Assembly for Concentrate
 164-8027
Cleaner Tubing #14 for Super Concentrate
 164-8025

Cleaner Tubing #16 for Regular Concentrate
 164-8026
Supply Tank Cap
 164-8081
Supply Tank Gasket
 164-0021

Cleaning

Complete Cleaner Tank Assembly - 164-8042 - FXW | FLX
Complete Supply Tank Assembly - 154-8840 - XF | KK | PX-C
Complete Cleaner Tank Assembly - 158-8433C - IKW | IKN | KW | ION-B,C,D | KP-B
Cleaner Supply Tank Only - 158-8433 - KW | ION-B,C,D | KP-B
Cleaner Supply Tank Only - 154-8894 - ION-A | KP-A
Cleaner Supply Tank Float Switch - 154-8693



Cushion Roller With Cloth Cover - 164-8839
Compatible with ALL IKON | ALL FLEX | KW | ION | XF | KP

Use same part number to upgrade these models: **KK**

If ordering to upgrade KK you will need (2)

153-6421S spacers and hardware (153-2069).

Cushion Roller - 153-8838 - KK
Duster Roll Support Pipe - 153-0429

PVC Take-Up Reel - 153-8824
(Not required with K2/K3 Select Cloth)
PVC Take-Up Reel Clamp - 154-6248 (Not Pictured)

Complete Squeegee Assembly (Blue) - 153-0202D
(Includes inside and outside channel)
KW | ION | XF | KP | KK



Replacement Squeegee Blades & Gasket Kit - 164-8038K
IKW | IKN | FXW | FLX (also for machines with upgraded Squeegee Cartridge)
Squeegee Gasket - 164-0003 - IKW | IKN | FXW | FLX (for machines with upgraded Squeegee Cartridge)



Replacement Squeegee Blades - Blue Pair - 153-8204E
Replacement Squeegee Blades - Brown Pair - 153-8834

Cleaner Tip Hose Assembly - 154-8852
IKW | IKN | FW | FX | FXW | FLX | KW | ION | KP

Pin Deck Treatment Hose Assembly - 164-8228
FW | FX | FXW | FLX

Pin Deck Treatment Tip Cover - 164-2067
FW | FX | FXW | FLX

Cleaner Tip with Check Valve
164-0012M



Male Luer
1/8" Hose Barb - 154-0863



Sprayless Cleaner Pumps



- Cleaner Pump Drive Motor
- 154-8874 (115V AC)
- 154-8875 (230V AC)
- 158-8404 (24V DC)
- Cleaner Pump Assembly - 158-8404D
- Norprene® Tubing - 154-0861B
- Cleaner Volume Control Valve - 154-1855
- Concentrate Motor (Upgrade Only)
- 164-8027 - FW | FX | FXW | FLX

Potentiometer for Cleaner Control

- 154-8846 - KP
- 158-8413 - KW | ION

Complete Cleaner Pump Assembly

- 154-8859 (115V AC) - KP-A
- 154-8859E (230V AC) - KP-A

Complete Cleaner Pump Assembly

- 158-8404C (24V DC) - KW | ION-A,B
- 154-8847 (24V DC) - KP-B

Kustodian PLUS (Model A Only)

24V DC Cleaner Pump Conversion Kit

- 154-8844 (115V AC)
- 154-8845 (230V AC)



- Cleaner Tank Filter - 154-0212B
- 1/2" O-Ring - 154-0287C

Cleaner Funnels

Cleaner Funnel - Long Stem

158-8252

Cleaner Funnel - Short Stem

154-8647

Cleaner Funnel - No Stem

153-0252



Spray Jet Cleaner Pumps

Kegel Cleaner Spray Pumps

- 158-8212 (115V AC)
- 158-8213 (230V AC)



Cleaner Pump Repair Kit

Valve/Diaphragm Kit for Kegel Pump

158-8212K

Spray Jet Assembly

- Tip Retainer - 153-0218
- Spray Jet Body - 153-6252
- Nylon Body - 153-0217



Screen Check Valve - 153-0220

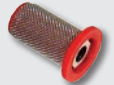

Outside Spray Tip (1501) - 154-0007

Inside Spray Tip (8003) - 153-0207

Inside Spray Tip (11003) - 153-0207A



Universal In-Line Filter Assembly - 154-8867A

In-Line Filter Assembly - 154-8887

IKW | IKN | KW | ION | KP

Cleaning System Tubing

(Sold by the Inch)

1/4" - 153-0208S - for Spray Jet Machines

1/4" - 154-0202C - Clear

LEGEND

SUFFIX

MACHINE

IKW	IKON WALKER
IKN	IKON
FWYEAR*	FLEX WALKER YEAR
FXYEAR*	FLEX YEAR
FXW	FLEX WALKER 2013-15
FLX	FLEX 2013-15

SUFFIX

MACHINE

KW	KUSTODIAN WALKER
ION	KUSTODIAN ION
XF	CROSSFIRE
KP	KUSTODIAN PLUS
KK	KUSTODIAN
PX-C	PHOENIX C

Some models have been discontinued, making some parts unavailable. Models include Elite (ELT), Standard (STD), Elite Plus (EP), Phoenix (PX), Phoenix-S (PXs)

* YEAR represents the model year in the serial number. Suffix represents all model variations unless model type is specifically indicated (i.e. KP-A).

Cleaning

Cleaning Component Motors

- Duster Motor (115V AC) - 153-8403 - KK | KP | XF
- Duster Motor (230V AC) - 153-8803H - KK | KP | XF
- Duster Motor (24V DC) - 158-8403 - ALL IKON | ALL FLEX | KW | ION
- Squeegee Motor (115V AC) - 153-8207 - KK | KP | XF
- Squeegee Motor (230V AC) - 153-8807 - KK | KP | XF
- Squeegee Motor (24V DC) - 158-8402 - ALL IKON | ALL FLEX | KW | ION
- Vacuum Motor (115V AC) - 154-8805 - KK | KP | PX-C
- Vacuum Motor (230V AC) - 154-8805E - KK | KP | PX-C
- Vacuum Motor (115V AC) - 158-8208 - XF
- Vacuum Motor (230V AC) - 158-8208E - XF
- Vacuum Motor (24V DC) - 158-8407 - ALL IKON | ALL FLEX | KW | ION



Vacuum Motor Replacement Parts

- Vacuum Housing - 153-0204H
- Fan Blade - 153-0204F
- Flexible Hose (Sold by the Inch) - 154-0260
- Vacuum Motor Hose Assembly (2021) 164-8840
- Squeegee Vacuum Hose Assembly (2021) 164-8841
- Squeegee Vacuum Hose Assembly (2021 - with tapped hole for suction elbow) 164-8842
- Vacuum Motor and Squeegee Hose Upgrade Kit (2021) 164-8843
- Vacuum Motor and Squeegee Hose Upgrade Kit (2021 - with suction elbow) 164-8844
- Brushes for Vacuum Motor (115V AC) - 153-0204B - KK | KP | PX-C | XF
- Brushes for Vacuum Motor (230V AC) - 153-0204C - KK | KP | PX-C | XF
- Brushes for Vacuum Motor (24V DC) - 158-1421B - ALL IKON | ALL FLEX | KW | ION

Cleaning Component Speed Controls and Head Motor Drivers

- Cleaner Speed Control (24V DC) - 164-8806 - ALL IKON
- Cleaner/Water Speed Control (24V DC) - 164-8221 - ALL FLEX
- Cleaner Speed Control (24V DC) - 158-8415 - KW | ION
- Cleaner Speed Control (24V DC) - 154-8848 - KP
- Stepper Driver (BERG) - 158-1605 - ALL FLEX | KW-C,D | ION C,D

WHAT IS NEW IN SPECTO BOWLING?

WORLDS

A guided game-like practice to help a player develop their skills. Just select the difficulty level and start with the first world. Improve your game while completing the missions

PERFORMANCE

Everything you need for a hard core practice. Learn about your ball reaction, accuracy, and see data related to your performance.

Challenges

Try different challenges to see how you stack up. Compete with bowlers in your center, country, and the world to get your name on the leader boards!



CHECK OUT THE BUSINESS MODELS and FINANCIAL PLANS AT

www.spectobowling.com

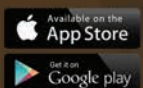

Conditioning

FLEX Conditioner Cartridge

(Complete with Valve Assembly) - 164-8015 (Pkg of 2)

FLEX Conditioner Cartridge

(Without Valve Assembly) - 164-8015A

Cartridge Plunger - 164-8015P

Cartridge Cap (with 38mm hole)

164-0004

Viton O-Ring for Cap

Viton O-Ring for Plunger (outside)

164-6079

Cable Carrier for Oil Head Assembly

164-9009- FW | FX

Oil Tip Assembly

164-8240 - FW | FX | FXW | FLX

FLEX Conditioner Sub Tank Float Switch

(For Old Style Molded Tank) - 154-8693

FLEX Conditioner Sub Tank Filter Assembly

(For Old Style Molded Tank) - 154-0212

Sub Tank O-Ring

(For Old Style Molded Tank) - 164-6173

Sub Tank Replacement Plug

(For Old Style Molded Tank) - 164-8082

Cylinder Sub Tank Upgrade Kit

164-8215

Cylinder Sub Tank Inline Filter Assembly

164-0215

Cylinder Sub Tank Float Switch

164-8237



Conditioner Transfer System

Single Conditioner Transfer Brush Assembly - 164-0866



Dual Conditioner Transfer Brush Assembly - 154-0866 - KW | ION | KP

Buffer Brush - 154-8641 - KW | ION | XF | KP | KK | PX-C

(Upgraded Transfer Brush to DUO System)

Buffer Brush - 164-8001 - FXW | FLX

Buffer Brush - 164-8001A - FW | FX

Transfer Roller - 154-8338 - PX-C

Transfer Roller - 154-8608 - KK

Transfer Roller - 158-8204 - XF

Transfer Roller - 164-8008 - IKW | IKN | ALL FLEX

Transfer Roller Duo Upgrade - 158-8441

Transfer Roller Belt Duo System 100XL037- 154-9203 - IKW | IKN | ALL FLEX

Buffer Belt 315L050 - 164-9019 - IKW | IKN

Buffer Belt 255L050 - 154-9615 - ION-A,B | KP | KK

Buffer Belt 225L050 - 153-9817 - PX-C

Buffer Belt 210L050 - 158-9201 - XF

Buffer Belt 263L050 - 158-9026 - KW | ION-D

Buffer Belt Standard 248L050 - 164-9006 - FXW | FLX

Buffer Belt for Variable Speed Upgrade 255L050- 154-9615 - FXW | FLX (FLX-17733 / FXW-13229 and ABOVE)

Buffer Belt for Variable Speed Upgrade 248L050- 164-9006 - FXW | FLX (FLX-17732 / FXW-13228 and BELOW)

Buffer Belt for Non-Variable Buffer 352L050 - 164-9016 - FW | FX

Buffer Belt for Variable Buffer 356L050 - 164-9017 - FW | FX



Head Drive Belt - 154-9201

Compatible with ALL applications.

Conditioning

Fluid Metering Components

1. Pulse Suppression Assembly

164-8021 - FXW | FLX

154-8816 - IKW | IKN | KW | ION | KP | KK

2. Pressure Gauge (60 psi) - 158-1613

3. Oil Control Valve (24V DC) - 154-1209

Oil Control Valve (24V DC - Extended Wires & Fittings) - 154-8298

4. Vent Valve

154-8817 - IKW | IKN | KW | ION | KP

164-8007 - FXW | FLX

5. Oil Tank Assembly with Fittings/Float

154-8682 - IKW | IKN | KW | ION | KP

Oil Tank Assembly with Fittings

154-8842 - KK

6. Oil Tank Filter - 154-0212

7. Float Switch Assembly

154-1203 - XF

154-8693 - IKW | IKN | FW | FX | FXW | FLX | KW | ION | KP | PX-C

8. Belt for Conditioner Pump Motor

154-9202A - IKW | IKN | KP | KK (60Hz)

164-9008 - ALL FLEX

158-8615 KW-C,D | ION-C,D

154-9202A for KW-B

154-9608 for ION-B

154-9215 KP | KK (50Hz)

9. Oil Tank Cap Assembly (only for tank pictured in diagram)

164-8081 - Complete

164-0021 - Gasket only

10. Fluid Metering Oil Pump

154-1214 - All Sanction Machines

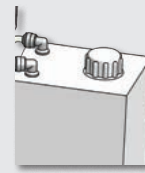
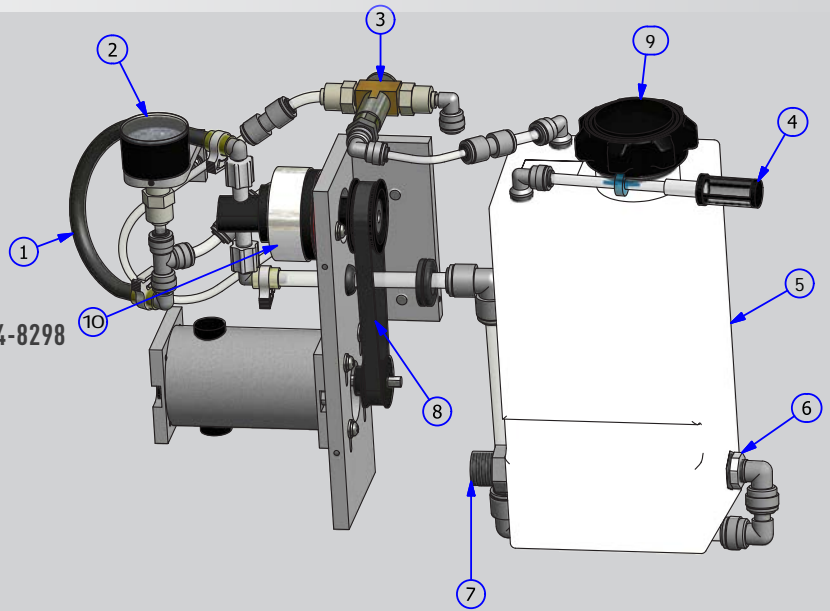

Oil Tank Cap Assembly

154-0832 - Complete

154-0832C - Cap only

154-0832G - Gasket only

Tubing

Conditioning System Tubing

(Sold by the Inch)

3/16" - 154-0202B

1/4" - 154-0202A

3/8" - 154-0202

Conditioner Head Tip & Hose Holder Assembly (includes tubing)

3- 1/2" Tip Holder (Painted Machines with Transfer Roller) - 154-8883

4- 1/2" Tip Holder (Painted Machines with Transfer Brush) - 154-8851

5- 1/4" Tip Holder (Upgraded Transfer Brush Models) - 154-8896

Retaining Spring for Head - 153-2713

Oil Pencil Tip (Black Molded) - 154-6832

Graduated Cylinder (25ml) - 154-0215

Felt for Graduated Cylinder (25ml) - 154-0210

Graduated Cylinder (50ml) - 154-0215A

Felt for Graduated Cylinder (50ml) - 154-0210A

Oil Funnel with 3" Hose - 153-0052A

Conditioner Pump Motors

115V AC - 154-8604 - KP | KK

230V AC - 154-8604E - KP | KK

24V DC - 158-8401A - IKW | IKN | KW-A,B | ION-A,B

24V DC Stepper Motor - 158-8632 - ALL FLEX | KW-C,D | ION-C,D

Motor Brushes for Conditioner Pump Motor

Bison® Motor Brushes (Black) - 158-1422B - KW-A,B | ION-A,B

Groschopp® Motor Brushes (Gray) - 158-1422G - IKW | IKN | KW-A,B | ION-A,B

(Note color of motor to ensure the correct brushes are ordered)

Head Drive Motors

115V AC - 154-8232 - KP | KK

230V AC - 154-8632 - KP | KK

24V DC - 158-8405 - IKW | IKN | KW-A,B | ION-A,B

24V DC Stepper Motor - 158-8632 - FW | FX | KW-C,D | ION-C,D

24V DC Stepper Motor - 164-8032 - FXW | FLX

Motor Brushes for Conditioner Head Motor

24V DC Brushes - 158-1404B - IKW | IKN | KW-A,B | ION-A,B

Brush Lift Motors

115V AC - 153-8207 - KK | KP | XF | PX-C

230V AC - 153-8807 - XF | KP | KK | PX-C

24V DC - 158-8402 - ALL IKON | ALL FLEX | KW | ION

Buffer Motors

115V AC - 154-8616A - XF | KP | KK | PX-C

230V AC - 154-8616E - XF | KP | KK | PX-C

24V DC (Standard Bodine®) - 164-8414 - IKW | IKN | ALL FLEX (Non Variable Buff)

24V DC (Bodine® Kit with Motor) - 164-8252 - KW | ION

24V DC (Variable Buff) - 164-8014A - ALL FLEX (Variable Buff Upgrade)

(Kit is needed when going from a Baldor® Buffer Motor to the new Bodine® Buffer Motor - NOT needed for 164-8252)

Buffer Motor Brushes

Standard Bodine® Buff - 164-1254

Variable Bodine® Buff - 164-1246

Conversion Kit for going to Bodine® Motor

Bodine® Drive/Buffer Motor Replacement Hardware Kit - 164-8250

(Kit is needed when going from a Baldor® Buffer Motor to the new Bodine® Buffer Motor - NOT needed for 164-8252)

Buffer Speed Control and Head Motor Drivers

Variable Buffer Speed Control - 164-8225 - ALL FLEX with VB Upgrade

Stepper Driver (BERG) - 158-1605 - ALL FLEX | KW-C,D | ION C,D

PLC

PLC Components*



- CP1H PLC (w/o Ports)- 158-1610P
- CP1L PLC (115V AC - w/o Ports)*- 164-1230 - XF | KP-A,B | KK
- CP1L PLC (24V DC - w/o Ports) - 164-1228 - KW-B | ION-B
- Serial Port Converter for CP1 - 158-1610S
- Analog Output - 164-1217 - FXW | FLX
- Analog Adapter- 164-1218
- ALL FLEX Machines with Buffer and/or Cleaner Upgrades
- Communication Cable - 164-1235 - IKW | IKN | FW19-22 | FX19-22
- Communication Cable - 158-1610D - FX16-18 | FXW | FLX
- Communication Cable - 158-1610CC - KW C,D | ION C,D
- Keypad Cable for CP1L and CPM2A - 154-8809
(When used for a CPM2A, use KOSI port top of PLC)
- Replacement Battery CP1L and CP1H - 158-1610B

Touchscreen Components



- Touchscreen Display 7"- 164-8203 - FW19-22 | FX19-22
- Touchscreen Protector 7"- 164-1245 - FW19-22 | FX19-22

- Touchscreen Display 5" - 158-8671 - KW C,D | ION C,D
- Touchscreen Display 5"- 164-8011 - FXW | FLX
- Touchscreen Protector 5" - 158-1612 - FXW | FLX

- Touchscreen Mounting Clip - 158-1610TC - FXW | FLX | KW-C,D | ION-C,D (set of 2)



- Touchscreen Display - 164-8803 - IKW | IKN | XF
- Touchscreen Protector - 164-1234 - IKW | IKN | XF

Replacement PLC Kits*

*The Omron® CPM2A PLC is no longer available and has been replaced by the Omron® CP1L PLC. A replacement kit has been designed to make the necessary modification in the event a new PLC is needed.

- DC Conversion Kit - 158-8454 - KW A,B | ION A,B
- AC Conversion Kit* - 158-8254 - XF-C | KP-A,B | KK | PX-C
- Twido To CP1L Upgrade (w/ 3.5" touchscreen) 158-8255 - XF-A,B

Additional upgrade kits may be necessary for KK-A,B | KP-A,B
Contact Kegel for more information.

154-8853C – Relay Kit for Original Kustodian
(Version 9G and above) *If not already in machine this kit is needed for PLC upgrade

154-8853Z – Relay Kit for Kustodian Plus
(Version 9Z and above) *If not already in machine this kit is needed for PLC upgrade

Omron® PLC Battery

154-1804 - CPM2A

Keypad Overlay Decal

154-0801K - KW-A,B | XF (Omron®) | KP | KK

Keypad Mounting Clips

(set of 2)

KW-A,B | XF (Omron®) | KP | KK

LEGEND

SUFFIX	MACHINE	SUFFIX	MACHINE
IKW	IKON WALKER	KW	KUSTODIAN WALKER
IKN	IKON	ION	KUSTODIAN ION
FWYEAR*	FLEX WALKER YEAR	XF	CROSSFIRE
FXYEAR*	FLEX YEAR	KP	KUSTODIAN PLUS
FXW	FLEX WALKER 2013-15	KK	KUSTODIAN
FLX	FLEX 2013-15	PX-C	PHOENIX C

Some models on the list have been discontinued, making some parts unavailable. Models include Elite (ELT), Standard (STD), Elite Plus (EP), Phoenix (PX), Phoenix-S (PXS)

* YEAR represents the model year in the serial number. Suffix represents all model variations unless model type is specifically indicated (i.e. KP-A).

KOSI Kegel Online Support Interface



Wi-Fi Connectivity Kit - 164-8821A

IKW | IKN | FXW19-22 | FLX19-22

Wi-Fi Connectivity Kit - 164-8821B

FW16-18 | FX16-18 | FXW | FLX

Wi-Fi Replacement Device - 164-8820A

IKW | IKN | ALL FLEX

KOSI Communication Kit - 154-8771B

USB to Serial Converter

KOSI Cable (32 or 64 bit)



USB to Serial Converter

157-1057



KOSI Cable

(32 or 64 bit) - 154-8724

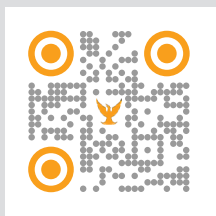

Get KOSI PRO for free at www.kegel.net

Batteries & Chargers

Kegel K2 Energy® Lithium Batteries



158-1634B (44.4 Ah)



158-1634C (59.2 Ah)

Batteries				
Machine Type	Lanes Per Charge	KEGEL Charger Being Used	Battery Available	Kit Needed
ION-A,B	Up to 62	Any	158-1634B	158-8654
KW-A,B	Up to 62	Any	158-1634B	158-8655
KW ION-C,D	Up to 62	Any	158-1634B	158-8655
	Up to 90	Any	158-1634C	158-8655
ALL IKON	Up to 62	ProNautic	158-1634B	None
ALL FLEX	Up to 90	ProNautic	158-1634C	None



ProNautic®
Chargers

Machine Type	ProNautic® Chargers	
	115V AC	230V AC
ION-A,B	158-8476	158-8476E
ION-C,D	164-8471P	164-8471PE
ALL IKON ALL FLEX KW	164-8471	164-8471E

*This is a kit that includes the ProNautic® Charger along with the necessary hardware to convert your machine to an external charging unit as the internal unit is no longer available.

ProNautic DC Power Cord Assembly (6 ft. External) 164-8475



Battery Disconnect Housing - Red
158-1407 (1 ea.)



Charger or Machine
Battery Disconnect Housing - Blue
158-1408 (1 ea.)



6 ga. Terminal - 158-1407A
10 ga. Terminal - 158-1407T

The disconnect housings automatically come with terminals for 10 ga. wire. If your lane machine has 6 ga. wire, order the 6 ga. terminals in addition to the housing.

CVR Replacement Kit (2016 FLEX and later) 164-8210

CVR Replacement Kit (KW and ION) 164-8083

Converted DC to DC Step Up Assembly - CVR (FX18-121 / FW18-182 and later) 164-8209

CVRs for all ION and WALKER models
contact Kegel.

CVR Fuse Adapter - 164-8206

Electrical Components

Power Cord Components

Description	115V AC	230V AC
Power Cord ION XF KP KK PX-C	154-8829	154-8830
Male Plug End (15A)	153-1025	153-1625
Male Plug End (20A)	153-1825	N/A
Female Twistlock Plug (15A)	153-1024	153-1624
Female Twistlock Plug (20A)	153-1822	153-1824
25' Charging Cord Assembly ION-A,B	158-8425	158-8425E



Push Button Replacements

Handle Button Replacement Assembly - 164-8013 - IKN | FLX
 Handle Button Replacement Assembly - 153-8424A - XF
 Handle Wire - 154-8893B - ION | KP
 Handle Button Replacement Assembly - 154-8824 - KK
 Power Up/Cleaner Test Button - 158-8439
 IKW | IKN | ALL FLEX | KW-C,D | ION-C,D

Head Motor 6.0µF Capacitor

154-1208 - KP | KK

Oil Pump Motor 1.5µF Capacitor

154-1208B - KP | KK

Breakers



Rocker Breaker 10A - 154-1272

Rocker Breaker 15A - 154-1610

Blade Type Fuses

Fuse 25A - 158-1439 for CVR - KW | ION

Fuse 30A - 164-1214 for CVR on VB Upgrade and

Pro Nautic® Charger - IKW | IKN | FXW | FLX

Fuse 40A - 158-1440 for IOTA® Battery Chargers

Maxi-Fuse 40A (for Fuse Link) - 158-1454 - ION

Fuse Link Assembly - 158-8421 - ION

Clear Cover for Electrical Panel

164-6183 - FW16-18 | FX16-18 | FXW | FLX

164-6062 - FW19-22 | FX19-22

164-6815 - IKW | IKN

Speed Control Cover

158-6702 - KW-C,D | ION-C,D

Replacement LED Light Kits

FLEX Arrow Light - 164-8079

Tank Light - 164-8024 - IKW | IKN | FW | FX | FXW | FLX

Fuse & Relay Kit



With these kits, you will have many of the small electronic pieces needed to keep you going. These kits contain three of each fuse used in the machine as well as fuse holders, spare relays, buttons, and switches.

154-8800F (115V AC)- KK-A,B

154-8800G (230V AC) - KK-A,B

154-8800J (115V AC)- KK-C

154-8800K (230V AC) - KK-C

154-8800R (115V AC) - KP

154-8800S (230V AC) - KP

154-8800C (115V AC) - XF

154-8800D (230V AC) - XF

158-8600F - KW-A,B | ION-A,B

158-8600G - KW-C,D | ION-C,D

164-8100F - FXW | FLX

164-8800F - IKW | IKN

Fuses

Panel Mount Fuse Holder (115V AC) - 153-1028

Fuse 0.5A (UL) - 154-1261

Fuse 0.5A Fast Acting (UL) - 154-1275

Fuse 0.75A (UL) - 154-1262

Fuse 1A (MDL) Ceramic - 155-1229C

Fuse 1.8A (UL) - 154-1265

Fuse 2.25A (UL) - 154-1266

Fuse 3.2A (UL) - 154-1267

Fuse 4A (UL) Ceramic - 154-1268C

Fuse 4A (UL) - 154-1268

Fuse 7.5A (UL) - 154-1270

Fuse 8A (UL) Ceramic - 154-1270C

Fuse 10A (UL) - 154-1273

Fuse 20A (UL) Ceramic - 154-1274C

Fuse 20A (UL) - 154-1274

Fuse 25A (MDA) Ceramic - 164-1222

Panel Mount Fuse Holder (230V AC) - 153-1028E

Fuse 315mA (IEC - 230V AC) - 154-1260E

Fuse 500mA (IEC - 230V AC) - 154-1261E

Fuse 1A (IEC - 230V AC) - 154-1264E

Fuse 1.6A (IEC - 230V AC) - 154-1265E

Fuse 4A (IEC - 230V AC) - 154-1267E

Fuse 6.3A (IEC - 230V AC) Ceramic - 154-1269C

Electrical Components

Omron® Brand Relays



LY2 Relay
153-1016D (24V DC Coil)
LY2 Relay
153-1016 (115V AC)
153-1616 (230V AC)



LY3 Relay
153-1018 (115V AC)
153-1618 (230V AC)



LY4 Relay
153-1406 (115V AC)
154-1611 (230V AC)



MY4 Relay
(24V DC)
158-1427



DPDT 10A
158-1462



PLC Output Relay (Short)
153-1032 (for Output Module OC221/OC222)
PLC Output Relay (Tall)
154-1215 (24V DC Coil - for Output Module OC222 only)

Omron® Relays for Sport Edition / FLEX / IKON Models

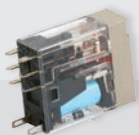

24V DC DPDT
158-1458



Solid State
158-1460



Super MY4 24V DC
(with Diode)
158-1463



LY3 Relay
(24V DC)
164-1231

Phoenix® Brand Relays



Secondary Relay Assembly
(24V DC)
154-1835 - KP | KK



2 Pole Relay
(10A - 24V DC)
158-1420G

Automation Direct® Relays



2 Pole Relay
(15A - 24V DC)
158-1413

Buffer Motor Contactor

115V AC
153-1004A (Din Rail Mount)

230V AC
153-1604A (Din Rail Mount)

Other Electrical Components



Duster Microswitch
(Large) 154-1603
IKN | FXW | FLX | KW | ION |
KP | KK | PX-C



Duster Microswitch
(Small) 153-1202
XF | PX-A,B



**Microswitch
with Roller**
153-1203
for ALL Machines



Squeegee Microswitch
(Large) 154-1015
PX-C



Arc Suppressor
158-1438



Proximity Sensor
154-1220

15K Resistor
(for cleaner speed control)
154-8848R

Proximity Sensor
158-1208 - XF-A



Contactor 24V DC
158-1465 - IKN | FXW | FLX
KW C,D | ION C,D
(Vacuum & Auto Shutdown
Relay)



Red Push Button
(Normally Open)
153-1408



Horsepower Resistor
0.025 Ω - 153-1015A
Horsepower Resistor
0.050 Ω - 153-1015



E-Stop Assembly for FLEX/IKON - 164-1223
(Includes Breaker, Black Box sold separately)
E-Stop Black Box for FLEX/IKON - 164-6161
FLEX E-Stop Breaker - 164-1223B
Prior to serial #FLX-17802 / FXW-13306 use part number 164-1223
(This will replace the discontinued Breaker and red triangle
shaped e-stop assembly)



2008 E-Stop (2-Hole Pattern)
154-1250A
Breaker for E-Stop
(2008 and later)
154-1251A

VOLTMETER TIPS



VOLTMETER SYMBOLS



**Alternating Current
V AC**
All 115V AC and 230V AC
machines that utilize a
power cord.



**Direct Current
V DC**
All battery operated
machines / also used to
drive AC powered machines.



Continuity Check
Used to inspect fuses and
circuitry. A beep will sound
when fuse or circuit is
closed.



BASIC VOLTMETER OPERATIONS

To check voltage:

1. Turn dial on the voltmeter to desired test.
2. Place each probe into the wires of the component you are testing and turn component on.

To check continuity:

1. Touch both probes together to inspect the voltmeter for proper function.
2. Place the test probes at each end of the circuit to be tested.
3. Voltmeter will sound if circuit is not broken. No sound if there is a break in the line.

TECH TIP:

Always inspect power cord ends and battery connections when electrical problems occur.

Electrical Components

MOLEX PLUGS



CONNECTOR	MALE	FEMALE
2 PIN	153-1041	153-1042
3 PIN	153-1044	153-1043
5 PIN	158-1206	158-1207
6 PIN	154-1231	154-1232
9 PIN	153-1039A	153-1040
12 PIN	153-1602A	153-1603
15 PIN	154-1807	154-1808
PINS	153-1046	153-1045
Pin Removal Tool		153-4002

HIGH AMP CONNECTORS



	PLUG	PIN
MALE	153-1063	153-1065
FEMALE	153-1064	153-1066

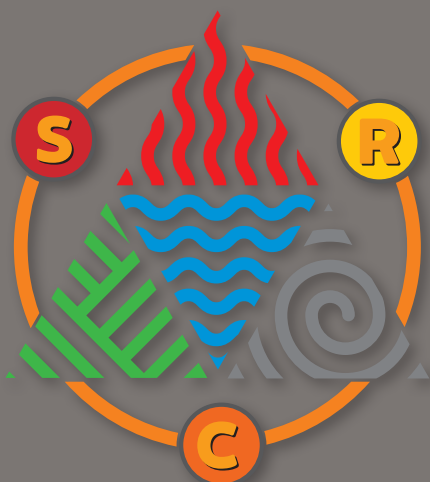

ELEMENT PATTERNS

DO YOU KNOW THAT KEGEL'S
ELEMENT PATTERNS
ARE SPECIFICALLY DESIGNED TO
WORK WITH ELEMENT
SERIES LANE CONDITIONERS?

Upgrades

DUO™ Transfer System

Transfer Brush System to DUO System
158-8430F

Smoother Pad Transfer System to DUO System
158-8430N - Only painted machines with transfer roller



Complete Squeegee Cartridge Assembly
164-8038

Handle Mount Kit
164-8253- IKN | FLX

Handle Reinforcement Kit
154-8284 - ION A,B | KP | KK

Crossfire Upgrades

Complete Upgrade - Includes 8 Wicks with Cam Roller and Large Conditioner Supply Tank
158-8241 (115V AC) | 158-8241E (230V AC)

Conditioner Tank Upgrade
158-8215 (115V AC) | 158-8215E (230V AC)

8 Pad Wick & Cam Kit - 158-8214



Fail Safe Beam - 164-8827 - FXW | FLX

Sub Tank Upgrade - 164-8215
All FLEX Machines

Kustodian Upgrades

Head Relay Upgrade Kit
154-8853C - KK-C

Drop Brush Upgrade Kit
154-8853Z - KP

Kustodian Model A to C Upgrade Kit - 154-8870
Serial Number: KK-0600 through KK-0810

Kustodian Model B to C Upgrade Kit - 154-8871
Serial Number: KK-0811 through KK-0987



Spray Pressure Regulator Upgrade
154-8268



Spray Jet Cup Assembly Upgrade
154-8692

Duster Plug Stud Kit (Set)
164-8817

Cushion Roller Arm Stud Kit (Set)
164-8822

Wheel Upgrades



6" Front Wheel Upgrade
Large 6" front wheel helps the lane machine transition on and off the lane with ease.
158-8733 ION | KP-B

3" Caster Upgrade

Dual 3" rear casters allow for better machine transition on and off the lane.

158-8731 KW | ION-C,D
158-8732 ION-A,B | KP-B

LED Light Upgrade Kit for Supply Tanks

Easily monitor the level of supplies on machines with plastic molded tanks with this light that automatically illuminates when the splash guard is opened.

158-8672 KW | ION | KP-A,B

Miscellaneous

Non-Adjustable Guide Rollers

Guide Roller - 153-8410
Guide Roller Shoulder Bolt - 153-2407
Guide Roller Mounting Bar - 153-6417
Guide Roller Spring - 153-2401
Plain Bushing - 153-9034
Flange Bushing - 153-9803

Adjustable Guide Rollers

Complete Front Assembly - 164-8846
Front Wheel Only (for 164-8846) - 164-8845

Complete Rear Assembly Black
164-8816 - all IKON and FLEX machines
Rear Wheel Only Black - 164-8815
Compression Spring - 164-2099
Complete Rear Guide Wheel Assembly White
158-8642 - KW-C,D | ION-C,D



Replacement Guide Rollers for 158-8643

Front Wheel Only - 158-8637
Rear Wheel Only - 158-8636

Tune Up Kits

IKW | IKN - 164-8800
FW19-22 | FX19-22 - 164-8030B
FW16-18 | FX16-18 - 164-8030A
FXW | FLX - 164-8030
KW - 158-8628
ION - 158-8428
KP (115V AC) - 154-8686
KP (230V AC) - 154-8687
KK | PX-C (115V AC) - 154-8888
KK | PX-C (230V AC) - 154-8888E
XF (115V AC) - 158-8288
XF (230V AC) - 158-8288E

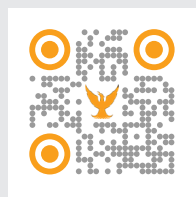

Get more
information
about
Tune-Up Kits

Replacement Felt

Felt (1/8" x 3") - (Sold by the Inch) - 154-0228S
Felt (1/8" x 9") - (Sold by the Inch) - 154-0628S
Felt Strip on Splash Guard Tank - 154-8333 - PX-C Only
Felt Kit for Transfer and Spray Jet Wall - 154-8669 - KK
Felt Strip for Transfer Wall - 154-8669A - KW | ION | KP
Felt Kit - 164-8212 - FXW | FLX

Momentary Wheel Assembly



Wheel - 153-7005R
Shaft - 153-6006
Housing - 153-6029

Caster Wheels

Lane to Lane Caster 2"
153-0812A (Wheel Only)
Lane to Lane 2" Caster Replacement
158-8222 (all models prior to 2019)



Lane to Lane 3" Caster
164-0022 - IKW | IKN | FX



Transport Caster
3" Dual Wheel (Black) - 153-0001BK
3" Dual Wheel (Gray) - 153-0001

Whiskers



Black Vinyl Cap - 153-2941 - IKW | FW | FXW | KW
Whisker Assembly
Left Whisker - 164-8824 - IKW | FW | FXW | KW
Right Whisker - 164-8825 - IKW | FW | FXW | KW
Left & Right Whisker only - 158-8624
IKW | FW | FXW | KW

Upgraded Whisker Assembly - 164-8826 - FXW | KW

Wicks



Glueless Wick Plate Assembly

3.125" - 153-8123

Only Compatible with PX-C

3.125" - 158-8223

Only Compatible with XF

5.125" - 153-8125

Only Compatible with PX-C

5.125" - 158-8225

Only Compatible with XF

7.125" - 153-8127

Only Compatible with PX-C

7.125" - 158-8227

Only Compatible with XF

10.125" - 158-8230

Only Compatible with XF



Not Pictured

45" Wick Material for Glueless Wicks - 153-0005B (5")

Wick Material Stock for Glueless Wicks - 153-0005D - XF

(Custom cut to be purchased by the inch)



Wick Spring (XF Only) - 153-2740

Solenoid Cable Assembly 8.25"
153-8812A (PX-C)

Transfer Roller Motors

153-8828 - 115V AC - XF

153-8829 - 230V AC - XF

154-8332 - 115V AC - PX-C

154-8332E - 230V AC - PX-C

**Kegel
Pinsetter
Parts
backed by
a 2 Year
Warranty**

**HAVE YOU
TRIED
PINSETTER PARTS
FROM KEGEL?**

**SCAN FOR
PINSETTER PARTS
CATALOG**



Fittings



Elbow
1/4" Tube x 1/4" Tube - 154-0243



Elbow
3/8" x 3/8" - 154-0256



Elbow
3/8" NPT x 1/4" Tube - 154-0412
3/8" NPT x 3/8" Tube - 154-0803



Elbow
3/8" Tube x 1/4" NPT - 154-0225
1/4" Tube x 1/4" NPT - 154-0223



Elbow
1/4" Stem x 1/4" Hose Barb
154-0226



Elbow
1/4" Stem to 5/16" Hose Barb
154-0227



Elbow
3/8" Stem to 5/16" Hose Barb
154-0239



Elbow
3/8" Stem x 3/8" Tube - 154-0258
3/8" Stem x 1/4" Tube - 158-1214



Elbow
1/4" Stem x 1/4" Tube
154-0222



Elbow
1/8" NPT x 3/16" Tube
154-0613



Reducing Union
1/4" x 3/16" - 154-0248
3/8" to 1/4" - 154-0244



Bulkhead Union
3/8" x 3/8" - 154-0285
1/4" x 1/4" - 154-0221



Union
1/4" x 1/4" - 154-0241



Union Tee
1/4" Tube - 153-0815



Male Connector
1/4" Tube x 1/8" NPT - 154-0224
1/4" Tube x 1/4" NPTF - 154-0858
3/8" Tube x 1/4" NPT - 154-0814



Female Connector
1/4" Tube x 1/8" FPT - 154-0257



Union Tee
3/8" Tube - 154-0815

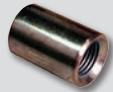

In-line Coupler
1/8" - 154-0230



Stem Adapter
1/4" NPT x 1/4" Stem
154-0243S



Male Connector
1/2" Tube x 1/2" NPT (Drilled)
154-0232D



Tank Plug
1/4" - 154-0245
3/8" - 153-1054
1/2" - 154-0231





O-Ring for Fitting
1/4" - 154-0287A
3/8" - 154-0287B
1/2" - 154-0287C





Two-Way Divider
1/4" Tube - 164-0201

Hardware







HEX HEAD CAP SCREWS

					
1/4		5/16		3/8	
7/8"	153-2052	1"	153-2061	1"	153-2066
1"	153-2053	1 1/4"	153-2062	1 1/4"	153-2067
1 1/4"	153-2054			1 1/2"	153-2068
1 1/2"	153-2055			2"	153-2069







MACHINE SCREWS PHILLIPS

					
# 6		# 8		# 10	
1/2"	153-2081	5/8"	153-2086	3/4"	153-2091
7/8"	153-2083	3/8"	153-2086A	1"	153-2092
1"	153-2084	3/4"	153-2087		
1 1/4"	153-2085	1"	153-2089		
		1 1/2"	153-2090		

WASHERS

		FLAT	LOCK
	#6	153-2001	
	#8	153-2002	
	#10	153-2003	153-2013
	1/4	153-2004	153-2014
	5/16	153-2005	153-2015
	3/8	153-2006	153-2016

HEX NUTS

		STANDARD	NYLOK	JAM
	#6		153-2018	
	#8		153-2019	
	#10	153-2022	153-2208	153-2524
	1/4	153-2023	153-2020	153-2304
	5/16	153-2024	153-2735	5/16-18 153-2027A 5/16-24 153-2214
	3/8	153-2025	153-2021	153-2027
	1/2	153-2026		

NYLON WASHERS

1/4 X 0.060	153-2510
1/4 X 0.030	153-2510A
5/16 X 0.060	153-2709
3/8 X 0.030	153-2531
3/4 X 1/16	153-2939
3/4 X 1/8	153-2938

Lids & Side Guards



FLEX 2013-2015 Model

Cleaner Compartment Lid - Red - 164-8031F
Cleaner Lid Compartment - Black - 164-8033F
Cleaner Lid Compartment - White - 164-8035F
Cleaner Lid Compartment - Blue - 164-8037F
Oil Compartment Lid - Red - 164-8031
Oil Compartment Lid - Black - 164-8033
Oil Compartment Lid - White - 164-8035
Oil Compartment Lid - Blue - 164-8037
Upper Right Guard - Non Walker - 164-6732-xxxx
Upper Left Guard - Non Walker - 164-6733-xxxx
Lower Right Guard - Non Walker - 164-8076-xxxx
Lower Left Guard - Non Walker - 164-8077-xxxx
Rear Panel - Non Walker - 164-8049-xxxx
Right Guard - Walker - 164-8074-xxxx
Left Guard - Walker - 164-8075-xxxx
Rear Panel - Walker - 164-8048-xxxx
Front Bumper - 164-8047-xxxx

IKON Model (ALL)

Cleaner Compartment Lid - 164-8801
Oil Compartment Lid - 164-8802
Upper Right Guard - Non Walker - 164-8811
Upper Left Guard - Non Walker - 164-8812
Lower Right Guard - Non Walker - 164-8809
Lower Left Guard - Non Walker - 164-8810
Rear Panel - Non Walker - 164-8808
Right Guard - Walker - 164-8233-2133
Left Guard - Walker - 164-8232-2133
Rear Panel - Walker - 164-8830
Front Bumper - 164-8804

Replacement Machine Rear Frame Panels

ALL IKON | FW | FX - 164-6004A-2850
FXW | FLX - 164-6004-2850
KW-C,D - 158-6672-2850
KW-A,B - 154-6860B-2915
ION-C,D - 158-6672-2911
ION-B - 154-6860B-2911
XF - 158-6205-2133
KP-B - 154-6860B-2915

FLEX 2016+ Model

Cleaner Compartment Lid - 164-8230-xxxx
Oil Compartment Lid - 164-8231-xxxx
Upper Right Guard - Non Walker - 164-6732-xxxx
Upper Left Guard - Non Walker - 164-6733-xxxx
Lower Right Guard - Non Walker - 164-8235-xxxx
Lower Left Guard - Non Walker - 164-8234-xxxx
Rear Panel - Non Walker - 164-8049-xxxx
Right Guard - Walker - 164-8233-xxxx
Left Guard - Walker - 164-8232-xxxx
Rear Panel - Walker - 164-8048-xxxx
Front Bumper - 164-8236-xxxx

COLOR CODES

BLUE	1525
BLACK	2850
RED	2911
WHITE	NO CODE

To order the correct color, place the color code number after the part number anywhere "xxxx" is listed.

KW | ION | XF | KP-B

Left Guard - KW - 158-6651
Right Guard - KW - 158-6650
Left Guard - ION-A,B | KP-B - 158-6418
Right Guard - ION-A,B | KP-B - 158-6419
Left Guard - ION-C,D - 158-6712
Right Guard - ION-C,D - 158-6711
Left Guard - XF - 158-6248
Right Guard - XF - 158-6249
Complete Lid - KP - 154-8892

Replacement Parts

Black Head Lid Decal - 164-0014
Black Tail Lid Decal - 164-0015
Silver Head Lid Decal - 164-0016
Silver Tail Lid Decal - 164-0017
FLEX Rear Wall Decals - 164-0008 (F-L-E) & 164-0009 (X)
Orange Head Lid Decal - 164-00140-714C
Orange Tail Lid Decal - 164-00150-714C
IKON Rear Wall Decals - Non Walker - 164-00230-714C (I-O-N) & 164-0024 (K)
IKON Rear Wall Decals - Walker - 164-0023W (I-O-N) & 164-0024 (K)
FLEX 13-15 Model Right Lid Track - 164-6118
FLEX 13-15 Model Left Lid Track - 164-6119
FLEX 16+ & IKON Model Right Lid Track - 164-6118A
FLEX 16+ & IKON Model Left Lid Track - 164-6119A
Lid Shim - 164-6170
Modified Spring Plunger - 164-2069M
FLEX 13-15 Model Left Cable Reels - 164-8039
FLEX 13-15 Model Right Cable Reels - 164-8040
FLEX 13-15 Model Lid Pivot Arm Plate (x2) - 164-8050A
FLEX 13-15 Model Right Pivot Arm - 164-6100A
FLEX 13-15 Model Left Pivot Arm - 164-6101A
Detent-Spring Plunger 3/8-16 Thread - 164-2002



**Flange Quarter
Turn Lid Latch**
154-0805



**Straight Quarter
Turn Lid Latch**
(With Slot) - 154-0804



Flush Mount Lid Latch
(With Lock) - 153-2232L



Push Latch with Key
154-0881

Drive Components

Drive Motors

24V DC (Bodine® 1.5" Shaft) - 164-8602B - IKN | ION-A,B
24V DC (Bodine® 2.5" Shaft) - 164-8602 - IKW (Left) | FW (Left) | FXW (Both) | FLX (Right) | KW-A,B | ION-C,D
24V DC (Bodine® 4.25" Shaft) - 164-8602A - IKW (Right) | FW (Right) | FX (Right)
90V DC (Baldor® to Groschopp® Kit) - 158-8260K - XF | KP | KK | PX-C
90V DC (Direct Replacement for Groschopp®) - 158-8260 - XF | KP | KK | PX-C
(If machine already has the Groschopp® motor then motor is only needed)
(Kit is needed when going from a Baldor® Drive Motor to the new Bodine® Drive Motor - NOT needed for 158-8260K)

Drive Motor Brushes

Bodine® - 164-1246
Groschopp - 158-1260B

Conversion Kit's for going to Bodine® Motors

Bodine Drive/Buffer Motor Replacement Hardware Kit - 164-8250 - IKN | FW | FX | ION-A,B
Bodine Drive Motor Replacement Hardware Kit with Brackets - 164-8251 - FW (Both) | FXW (Both) | KW | ION-C,D
(Kit is needed when going from a Baldor® Drive Motor to the new Bodine® Drive Motor - NOT needed for 158-8260K)

Baldor® Motor Replacements Parts (Drive, Standard Buff and Variable Buff)

Real Seal - 154-1809D

Front Seal (Shaft Side) - 154-1809E

24V DC Drive/Variable Buff Motor Brushes - 158-1405B

24V DC Buffer Motor Brushes - 158-1406B

90V DC Motor Brushes - 154-1809B

Note: The Baldor® motors were discontinued and replaced with the current Bodine® motors

Speed Control Boards

164-8828 – IKW | ALL FLEX

164-8807 – IKN

158-8412 – ION-A,B

164-1242A – ALL KW | ION-C,D (RAW BOARD used in 164-8828)

158-1410 – RAW BOARD used in 158-8412

153-1012 (115V AC) – KP | KK | PX-C

153-1812 (230V AC) – KP | KK | PX-C

158-1212R (115v-230V AC) – XF

Circuit Board with Speed Relays

154-8810 (115V AC) – KP | KK

154-8811 (230V AC) – KP | KK

158-8409 (24V DC) – ION-A,B

CHAINS & ACCESSORIES				
DESCRIPTION	IKW	FLEX 13-15	FLEX 16 AND UP	KW
MAIN DRIVE	NA	154-9601 (40P41)	154-9601 (40P41)	158-9612 (40P43R)
LEFT SIDE ZTR	164-9018 (40P23)	153-9814 (40P33)	153-9044A (40P29)	158-9609 (40P55R)
RIGHT SIDE ZTR	153-9044A (40P29)	153-9444 (40P31)	164-9018 (40P23)	158-9609 (40P55R)
ZTR DRIVES ZTR WHEELS	NA	164-9005 (35P67)	164-9005 (35P67)	NA
SMALL ZTR DRIVES 6 TOOTH STAR	NA	164-9004 (25P55)	NA	158-9607
SPROCKET DUPLEX FOR ZTR	NA	164-9002	NA	NA
SECONDARY DRIVE	NA	164-9010 (35P83)	NA	NA
SECONDARY DRIVE SPROCKET	NA	164-9011	NA	NA
SECONDARY REAR DRIVE IDLER SPROCKET	NA	164-8005	NA	NA
ZTR KICKUP	164-9005 (35P67)	NA	NA	NA

MAIN DRIVE CHAINS	
MACHINE	PART #
IKON	154-9601 (40P41)
ION SPORT	158-9612 (40P43R)
ION B	158-9405 (40P45R)
KUSTODIAN PLUS	153-9814 (40P33)
KUSTODIAN	153-9814 (40P33)
CROSSFIRE	158-9203 (40P39)

MASTER LINKS	PART #	OFFSET LINKS
#25	153-9045	NA
#35	153-9046	158-9022
#40	153-9047	153-9048

Chains may require master and half links. Please contact Kegel with any questions.

NO BOWLER LEFT BEHIND

Bowling's first lane conditioner
that adapts to a bowler's
playing style.



Terrain features shear-thinning chemical technology which responds differently to each individual bowler. The result is a single lane conditioner that is more forgiving for your center's wide range of bowlers.



PRODUCTS & PARTS

2021-22

www.kegel.net

Toll Free (US Only):
800 - 280 - BOWL (2695)
Fax: 863 - 734 - 0204
International: 863 - 734 - 0200

1951 Longleaf Boulevard
Lake Wales, FL 33859 USA